

A PRECISION DRILL PRESS FOR SMALL HOLES



Our highly-reliable Precision-Sensitive Drill Presses meet the needs of single hole drilling applications in the range of 0.004" to 0.250" (0.1mm to 6.4mm). Our Drill Presses are available with a choice of Albrecht keyless chuck, or WW collets, as well as inch or metric gauges. With an adjustable spindle speed range of 200 to 20,000 RPM, our Drill Presses cut through most materials; such as carbon steel, stainless steel, non-ferrous metals, plastics, graphite and printed circuit boards, plus diamond drilling in ceramics, sapphire and glass.



WITH THE SENSITIVITY TO LET YOU FEEL THE DRILL

FEEL THE DRILL

You can actually feel the cutting forces on the drill with our sensitive rack and pinion drive system. Scrapped parts and drill breakage can be minimized.

Each drill press provides smooth and quiet operation, because belt tension is placed on the separate carrier ball bearings in the spindle drive assembly and not on the bearings in the spindle. The spindle is driven by a high-strength mechanism with precision balanced rotating parts.

DRILL WITH PRECISION

Perform precision drilling operations easily with a fully adjustable quill lever, plus the adjustable and calibrated quill stop can be utilized as an up or down stop. This allows the quill to be locked in a fully-extended up or down position.

The quill stop can also be used as a fine down feed or as a continuously adjustable down stop for controlled incremental pecking which makes deep hole drilling easy.

MICROPROCESSOR CONTROL OPTION

An optional microprocessor-controlled quill feed for peck and reaming cycles optimizes production, as well as minimizing tool wear and breakage by delivering controlled feed rates up to 30 IPM.

Our quill feed is designed to provide accurate hole depths within +/- 0.001" while automatic pecking action clears chips, reduces drill wander and allows deep holes routinely and accurately with small drills.

An optional foot switch is available, which provides the maximum freedom of hand movement. Manual jog keys and data entry buttons with LED readout permit easy program scanning and modification.

Four modes of operation are offered; Auto, Single Step, Ream, and Program. In auto mode, the cutting tool performs a pecking sequence that begins with a rapid plunge to a programmable distance above the previous cut, controlled feed to a new depth, followed by a rapid



M-9090 shown with T-Slot base

retraction to a programmable distance above the work surface and selectable dwell time that allows chips to clear.

The Single Step mode enables the program to be checked one peck at a time.

In the Ream mode, feed rates are controlled during both the plunge and retract strokes.

In the Program mode, the operator can set quill sequence control values.

HIGH PERFORMANCE OPTIONS

- Our latest high torque / heavy duty head provides 1/4 HP, enough to drill a 1/4" hole in steel or up to 3/16" in surgical stainless steel, but still gives you the precise feel and control to drill .004".

- We also recently introduced our steel base with "T" slots for easier clamping of vises and other fixtures.

- Our Tool Kit is a complete accessory package assembled to give you all the tooling necessary to perform most any operation on your drill press.

- Our drill tap control unit eliminates the need for a separate tapping attachment.

- The unique design of the mill head adaptor kit lets you attach our drill press head to the R8 taper of any Bridgeport-type quill and locks it together as one unit to enable use of a rigid X-Y table.

RELIABLE ACCURACY FOR ALL APPLICATIONS

With built-in accuracy and reliability, our drill presses deliver maximum performance in manufacturing and assembly areas, as well as in laboratories and engineering departments where precision production and prototype jobs are common tasks. For example: medical devices, jewelry, automotive, electronics, musical instruments as well as EDM and mold parts -- just to name a few!



M-0728 Drill Press Tool Kit

Accessory Tool Kit includes:

1" precision mini vise
2" precision screwless vise
Two "V" blocks
Precision fence w/ work stop
Four piece clamping kit
#61-80 drill bit set

STANDARD DRILL PRESS

For laboratory, prototype and precision production work.

12" (304.8mm) Column Versions

Inch	Metric	Type
7000	7100	Albrecht Chuck
7050	7150	WW Collet

19" (482.6mm) Column Versions

Inch	Metric	Type
7010	7110	Albrecht Chuck
7060	7160	WW Collet



Mounts to all Servo drill presses
Includes depth gauge and stop

Peck steps	0.001"-1.4" (.02-35.6mm)
Accurate hole depth	0.001" (0.02mm)
Quill travel	1.4" (35.6mm)
Max. quill force	35 lb. (16 kg.)
Controlled feed rate	0.01-30 ipm 0.25-750mm/min.
Inch/Metric (L)x(W)x(H)	8.5" x 6.5" x 4.5" 21 x 17 x 11 cm
Electrical	115 VAC, 50Hz, 0.3A, 40W



MICROPROCESSOR-CONTROLLED QUILL FEED

Model 708 for peck drilling and reaming cycles, plus routine drilling of deep holes (Factory installed). Optional footswitch M-710.

HEAVY DUTY DRILL PRESS

With more horsepower

Mounts to all Servo bases
Includes depth gauge and stop

Inch	Metric	Type
9000	9100	Albrecht Chuck
9050	9150	WW Collet

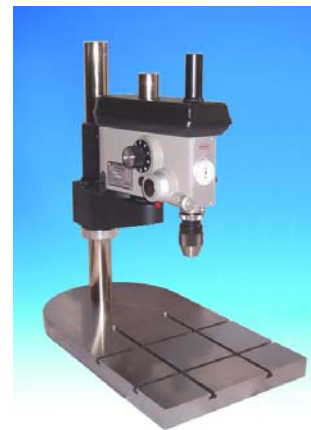

Shown with T-Slot base

Modifies head with 3-position toggle switch for selecting drill or tap mode

Features:

- Multi-pin electrical receptacle to connect foot switch control for reversing
- Normal machine operation remains unchanged

- Motor runs at lower speed range in tap mode with foot switch reversing for tapping to desired depth then instantly reversing to bring the tap out

- Tapping capacity in steel: #0000 - #4 / M0-M3

- Factory installed option



DRILL-TAP CONTROL

Model 709 includes footswitch to reverse the spindle direction which eliminates the need for a separate tapping attachment.

T-SLOT BASE

For use with clamping kit

Inch	Metric	Type
9080	9180	Albrecht Chuck
9090	9190	WW Collet

DRILL PRESS with

UNIQUE OFFSET COLUMN

For a wide workpiece, such as a PC board.

Lets you drill to center of a 17"(431.8mm) circle

Inch	Metric	Type
7030	7130	Albrecht Chuck



STANDARD HEAD

Inch	Metric	Type
7400	7403	Chuck
7401	7404	WW collet

HEAVY DUTY HEAD

Inch	Metric	Type
9400	9403	Chuck
9401	9404	WW Collet



DRILL PRESS HEAD ONLY

Shown w/quill lock option for milling. Models: 7405/7406 for Std head, 9405/9406 for Heavy Duty head.

DRILL PRESS with ELBOW and DEEP THROAT

For larger workpieces.

Up to 14"(355.6mm) working area/depth under the quill

Inch	Metric	Type
7040	7140	Albrecht Chuck
7070	7170	WW Collet



X-Y table enhances performance by providing milling capabilities

Features / Options:

- Various sizes to fit application requirements
- Ballscrews available
- Precision ground ways
- DRO available
- Z-axis slide available



PRECISION DRILL PRESS SPECIFICATIONS

- Keyless Albrecht chuck: 0-1/8" / 0-3 mm standard; (optional 0-1/16" / 0-1.5 mm); quick and easy drill changes
- WW collet versions 0.0039"-0.252"/0.1-6.4 mm for less run out and improved accuracy because tool is supported closer to the spindle
- Precision ground column with head column lock
- Self-contained motor with aluminum housing; on/off switch
- Coarse depth dial 0.1"/division or 5 mm/division
- Dial gauge 0.001" or 0.05 mm/division for accurate depth control
- Dial gauge zero set knob
- Inch and metric versions
- Adjustable, sensitive quill lever - turn to adjust position
- Adjustable down stop for blind-hole drilling 0.001" or 0.05 mm/division
- Quill travel (stroke): 1.5" / 38.1 mm
- Infinitely variable spindle speeds: 200 to 20,000 rpm over two belt ranges (low ratio: 200 to 4,000 rpm; high ratio: 1,000 to 20,000 rpm)

- Spindle runout: 0.0002" / 0.005 mm TIR
- Drill Press machining capabilities:
 - Inconel: Std D/P drilling to 1/16"; Heavy Duty D/P to 1/8"
 - Steel: Std D/P drilling to 1/8"; Heavy Duty D/P to 1/4"
 - Aluminum: Std D/P drilling to 3/16"; Heavy Duty D/P to 1/4"
- Electrical: 115 volts AC, 50/60 Hz, 2 amps (220V/115V transformer available)
- Weight: 21-92 lbs./9.5-41.7 kg
- Shipping dimensions:
 - Models 7000/7100; 7050/7150: 7.15"W x 11.8"D x 13.5"H
181.61mm W x 299.72mm D x 342.9mm H
 - Models 7010/7110; 7060/7160: 7.15"W x 11.8"D x 20"H
181.61mm W x 299.72mm D x 508mm H
 - Models 7030/7130; 7040/7140; 7070/7170; 7080/7180; 7090/7190
10.5"W x 18.5"D x 20"H; 266.7mm W x 469.9mm D x 508mm H
- * Shipping dimensions are the same for equivalent 9000 series models

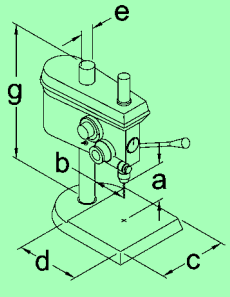
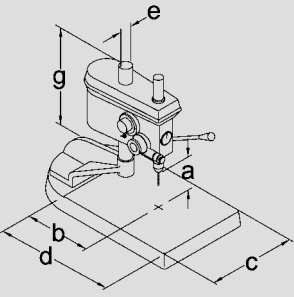
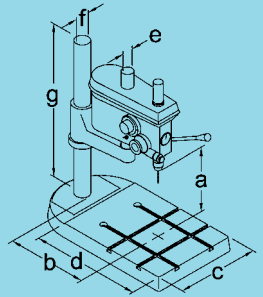
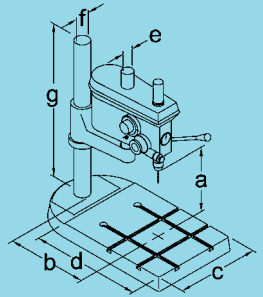
<p>Standard Drill Press 7000 / 7100 7010 / 7110 7050 / 7150 7060 / 7160</p>  <p>Heavy Duty Drill Press 9000 / 9100 9010 / 9110 9050 / 9150 9060 / 9160</p>	<p>Drill Press with Unique Offset Column 7030 / 7130</p>  <p>Heavy Duty Drill Press 9030 / 9130</p>	<p>Drill Press with Elbow and Deep Throat 7040 / 7140 7070 / 7170</p>  <p>Heavy Duty Drill Press 9040 / 9140 9070 / 9170</p>	<p>Drill Press with Elbow and T-Slot Base 7080 / 7180 7090 / 7190</p>  <p>Heavy Duty Drill Press 9080 / 9180 9090 / 9190</p>
---	--	---	---

Inch	7000 / 9000	7010 / 9010	7050 / 9050	7060 / 9060	7030 / 9030	7040 / 9040	7070 / 9070	7080 / 9080	7090 / 9090
Metric	7100 / 9100	7110 / 9110	7150 / 9150	7160 / 9160	7130 / 9130	7140 / 9140	7170 / 9170	7180 / 9180	7190 / 9190
[a] Maximum distance of chuck or collet to base	6" 152mm	13" 330mm	7.5" 190mm	14.5" 368mm	6" 152mm	16.5" 419mm	18" 457mm	16.5" 419mm	18" 457mm
[b] Throat depth (spindle center to column)	3.5" 89mm	3.5" 89mm	3.5" 89mm	3.5" 89mm	8.5" 216mm	9.9" 252mm	9.9" 252mm	9.9" 252mm	9.9" 252mm
[c] Working base area (width)	6.5" 165mm	6.5" 165mm	6.5" 165mm	6.5" 165mm	9.75" 248mm	9.75" 248mm	9.75" 248mm	9.75" 248mm	9.75" 248mm
[d] Working base area (depth)	6.5" 165mm	6.5" 165mm	6.5" 165mm	6.5" 165mm	13.25" 336mm	13.25" 336mm	13.25" 336mm	13.25" 336mm	13.25" 336mm
Total base width	7.15" 181mm	7.15" 181mm	7.15" 181mm	7.15" 181mm	10.5" 267mm	10.5" 267mm	10.5" 267mm	10.5" 267mm	10.5" 267mm
Total machine depth	11.8" 299mm	11.8" 299mm	11.8" 299mm	11.8" 299mm	18.5" 470mm	18.5" 470mm	18.5" 470mm	18.5" 470mm	18.5" 470mm
Total machine height	18" 457mm	25" 635mm	18" 457mm	25" 635mm	18" 457mm	29.5" 749mm	29.5" 749mm	29.5" 749mm	29.5" 749mm
[e] Column diameter through head	1.25" 31mm	1.25" 31mm	1.25" 31mm	1.25" 31mm	1.25" 31mm	1.25" 31mm	1.25" 31mm	1.25" 31mm	1.25" 31mm
[f] Column diameter through elbow	-	-	-	-	-	1.625" 41mm	1.625" 41mm	1.625" 41mm	1.625" 41mm
[g] Column length	12" 305mm	19" 483mm	12" 305mm	19" 483mm	7.5" 191mm	18" 457mm	18" 457mm	18" 457mm	18" 457mm
Base	Fine grain, ground cast iron base				Fly-cut cast aluminum base with cast iron offset and elbow			Steel T-Slot base with cast iron offset and elbow	

DRILL PRESS OPTIONS & ACCESSORIES

- WW Collets, 0.0039" -0.252" [0.1mm - 6.4mm]
- WW Arbor to Jacobs "0" taper allows chucks to be used in collets
- Precision fence gauge (Model 727)
- Accessory tool kit (Model 728)
- Dual column/dual head (Model 729)
- Albrecht keyless chucks, 0-1/8" (0-3 mm) and 0-1/16" (0-1.5mm)
- 220V Power kit converts 220 to 115 VAC
- Jacobs key chuck, 0-5/32" (0-4 mm)
- Standard mill R8 taper adaptor kit (Model 705) (enables mounting of head to milling machine)
- Quill lock option (for milling)
- Microprocessor-controlled quill feed (Model 708)
- Micro quill feed foot switch (Model 710)
- Drill-tap control with foot switch (Model 709)
- Through hole option available on Albrecht chuck versions (0.05" diameter)
- Bases and heads can be purchased separately
- Tilt & rotate articulating head bracket

Proudly manufactured in the USA by

Servo Products Company

Toll Free 800.521.7359 Web: www.servoproductsco.com



A HIGH QUALITY TOOLS Partner Company

HEADQUARTERS

34940 Lakeland Blvd.
Eastlake, OH 44095

Ph. 440.942.9999 Fax 440.942.9100

CALIFORNIA BRANCH

1355 W. Foothill Blvd.
Azusa, CA 91702

Ph. 626.691.0121 Fax 626.334.7301

FLORIDA BRANCH

8950 131st Ave. N.
Largo, FL 33773

Ph. 727.585.8555 Fax 727.585.6555