



TURBO DRIVE INSTALLATION

MODEL 9522T CROSS FEED

Servo SV 50 & SV 54

➔ **NOTE** This Turbo Drive Cross Feed is configured for mounting the feed on the front of the knee with the keypad facing right. The lead screw pitch is 5 turns per inch left hand. See **CAUTION** below before changing anything!

CAUTION

The Turbo Drive power cable should be left **unplugged** until the drive is properly installed on the lead screw.

See the **Operation** manual to reverse the direction of travel or to change the lead screw pitch default. Turn **off** the Turbo Drive and **remove** the power plug from the wall before you attempt to change any jumpers or reverse the top housing.

WARNINGS

DO NOT install and operate this power feed without safety handwheel Servo #58923 on the front side of the cross. This is required to prevent injury.

Check handwheel clearances before operation.

Clearances between the surfaces of the handwheel and the non-moving parts of the equipment on which the handwheel is installed must be at least one-fourth inch (1/4") to prevent injury.

Do not operate without proper clearance!

Prevent contact during fast traverses.

WARRANTY CAUTION

There are **NO** user-serviceable parts inside the center or bottom housings. Removal of the motor, keyboard, or bottom housing screws **voids** the warranty.

REFERENCE DRAWINGS ENCLOSED

NA-58496	Bevel Gear Installation
NB-58626	Turbo Drive Installation
0800-80678	Turbo Drive Operation manual

PREPARATION

Step 1: Gather together the following items that you will need to complete this installation.

- a) 3/8" electric hand drill
- b) #7 drill, 1/8" drill, 9/32" drill
- c) 1/4-20 tap
- d) 9/32" diameter transfer punch

- e) ball peen hammer & support piece
- f) flat file
- g) 3/4" socket wrench
- h) set of inch hex wrenches
- i) grease
- j) masking tape
- k) clean shop rag

Step 2: Clean the power feed mounting area completely.

Step 3: Remove the nut, handle, and dial assembly from the front end of the cross. Keep the dial for reuse later.

MOUNTING HARDWARE INSTALLATION

Step 1: Slip the bearing race #0334 onto the lead screw shaft.

Step 2: Slip the power feed unit over the bearing race and position against the front of the knee.

Step 3: Select two of the eight mounting holes on the unit such that it can be mounted vertically and rigidly. Using a 9/32" diameter transfer punch, transfer the mounting holes to the bearing retainer.

Step 4: Remove the unit and the bearing race. Mask the bearing in the bearing housing. Drill #7 through the bearing retainer and 1" into the bearing housing. Remove the bearing retainer to open its holes to .281" diameter clearance holes. Tap 1/4-20 UNC threads by 1/2" deep into the bearing housing.

Step 5: Lubricate the shaft with a light coat of grease. Slip the bearing race back onto the shaft. Then slip the adaptor over the race to center it with the shaft. Keeping the portion of the race sticking out beyond the counterbored end of the adaptor so that it can be removed later, slide both pieces to locate the adaptor against the cross bracket. Secure the adaptor with three 1/4-20 x 1-3/8 long socket head cap screws provided. Remove the bearing race.

SHAFT EXTENSION AND TURBO DRIVE INSTALLATION

Step 1: Screw on the shaft extension #1556 onto the lead screw and tighten.

Step 2: Following the existing pilot hole, drill through the shaft extension using a 1/8" diameter drill.

Step 3: Support the other side of the hole and hammer in the #00596 roll pin. File smooth and clean thoroughly.

Step 4: Slide the Turbo Drive onto the bearing race and push against the front of the bearing housing. Secure with two 1/4-20 x 1-5/8" long socket head cap screws.

IF: If the bearing race is not flush with the needle bearing in the unit within $\pm.05$ ", then either shim behind the race or machine the spacer to correctly locate the race.

BEVEL GEAR INSTALLATION

Step 1: Follow the drawing NA-58496 for installation of the bevel gear. Adjust for proper gear backlash.

DIAL AND HANDWHEEL INSTALLATION

Step 1: After getting the proper gear backlash, the dial should be adjusted to obtain .005" spacing from the face of the power feed. This is important in order to keep chips from entering the gear train. Three plastic (.030" thick) and five brass (.005" thick) washers are provided for this. Shim as required.

Step 2: In the following sequence, install the key #04986, dial and dial nut #2255. Slide the handwheel #58923 in place and tighten with 1/2-20 locknut #01115.

TURBO DRIVE OPERATION

See the separate **Servo Turbo Drive Operation** manual for complete operating instructions. Plug the unit into a properly grounded three-wire outlet supplying 110 volt single phase 50/60 Hz 6 amp power. Turn the control switch ON and follow the instructions in the manual or on the **Quick Reference** sheet for setting limits.

SERVO PRODUCTS COMPANY

433 North Fair Oaks Avenue, Pasadena, CA 91103 USA
Phone: 800.521.7359 or 626.796.2460 Fax: 626.796.3845

Web: www.servoproductsco.com

If service is required, call Servo Products Company.

DO NOT PLUG IN POWER UNTIL ALL STEPS ARE COMPLETED.

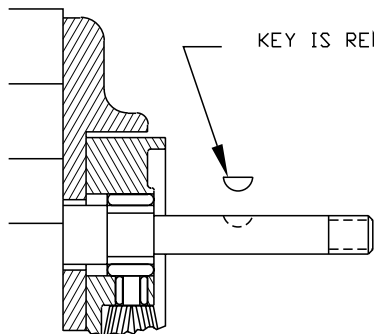

KEY IS REMOVED DURING SHIMMING

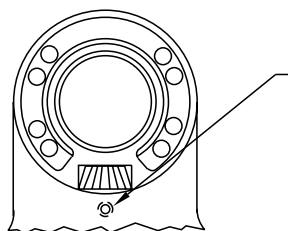

TIGHTEN SLIGHTLY (HOLDS BEVEL PINION STATIONARY DURING SHIMMING.)
(TIGHTEN UPPER ONE ONLY)

STEP 1
PREPARATION

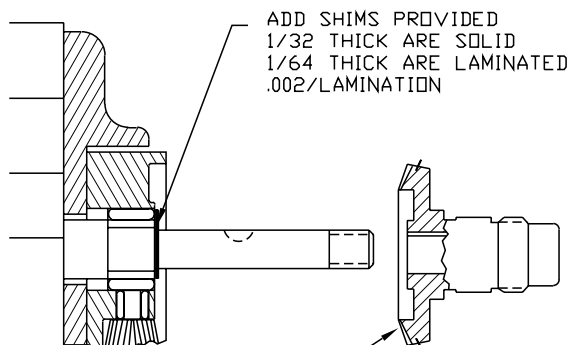

ADD SHIMS PROVIDED
1/32 THICK ARE SOLID
1/64 THICK ARE LAMINATED
.002/LAMINATION

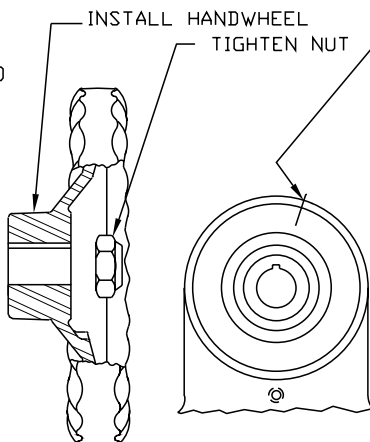

INSTALL HANDWHEEL

TIGHTEN NUT

SCRIBE ACROSS GEAR & HOUSING WHILE PUSHING GEAR AGAINST ONE SIDE OF THE BACKLASH

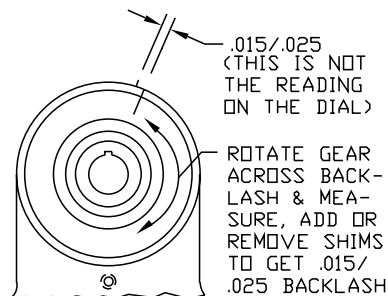

.015/.025
(THIS IS NOT THE READING ON THE DIAL)

ROTATE GEAR ACROSS BACKLASH & MEASURE, ADD OR REMOVE SHIMS TO GET .015/.025 BACKLASH

PUSH BEVEL GEAR AGAINST SHIMS.

STEP 2
SHIMMING BEVEL GEAR

CAUTION: IF BACKLASH IS NOT PROPERLY SET BEFORE TURNING UNIT ON, BEVEL GEAR MAY BE DESTROYED.

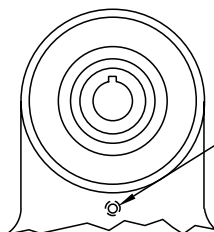

LOOSEN SETSCREW

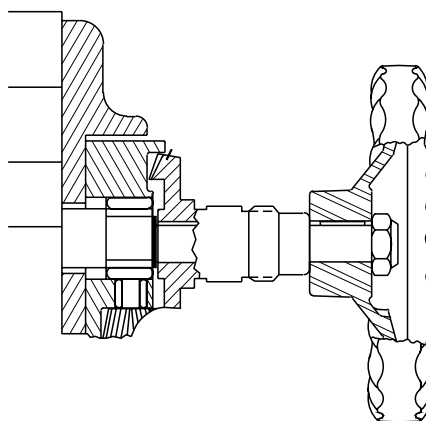

MANUALLY TURN HANDWHEEL. IF EXCESSIVE GEAR NOISE OR BINDING OCCURS, SHIMS NEED TO BE ADDED OR REMOVED, WHEN RE-SHIMMING, REPEAT STEPS 1 AND 2.

STEP 3
DOUBLE CHECK OF SHIMMING

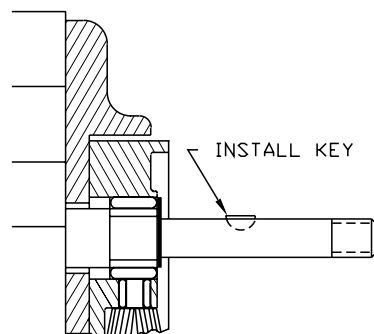

INSTALL KEY

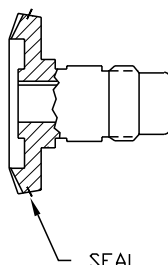

SEAL

REMOVE GEAR, PACK WITH GREASE. (DO NOT USE SILICONE TYPE GREASE) REPLACE GEAR. (DO NOT LOSE ANY SHIMS)

PICTURES IN THIS DRAWING ARE FOR REFERENCE ONLY. SEE INSTALLATION DRAWING OF CORRESPONDING MODEL FOR EXACT PARTS CONFIGURATION.



SERVO PRODUCTS COMPANY

BEVEL GEAR INSTALLATION

NA-58496

STEP 4
LUBRICATION

REVISION		DATE	DRAWN	CHECKED
ECD	LTR	DESCRIPTION		

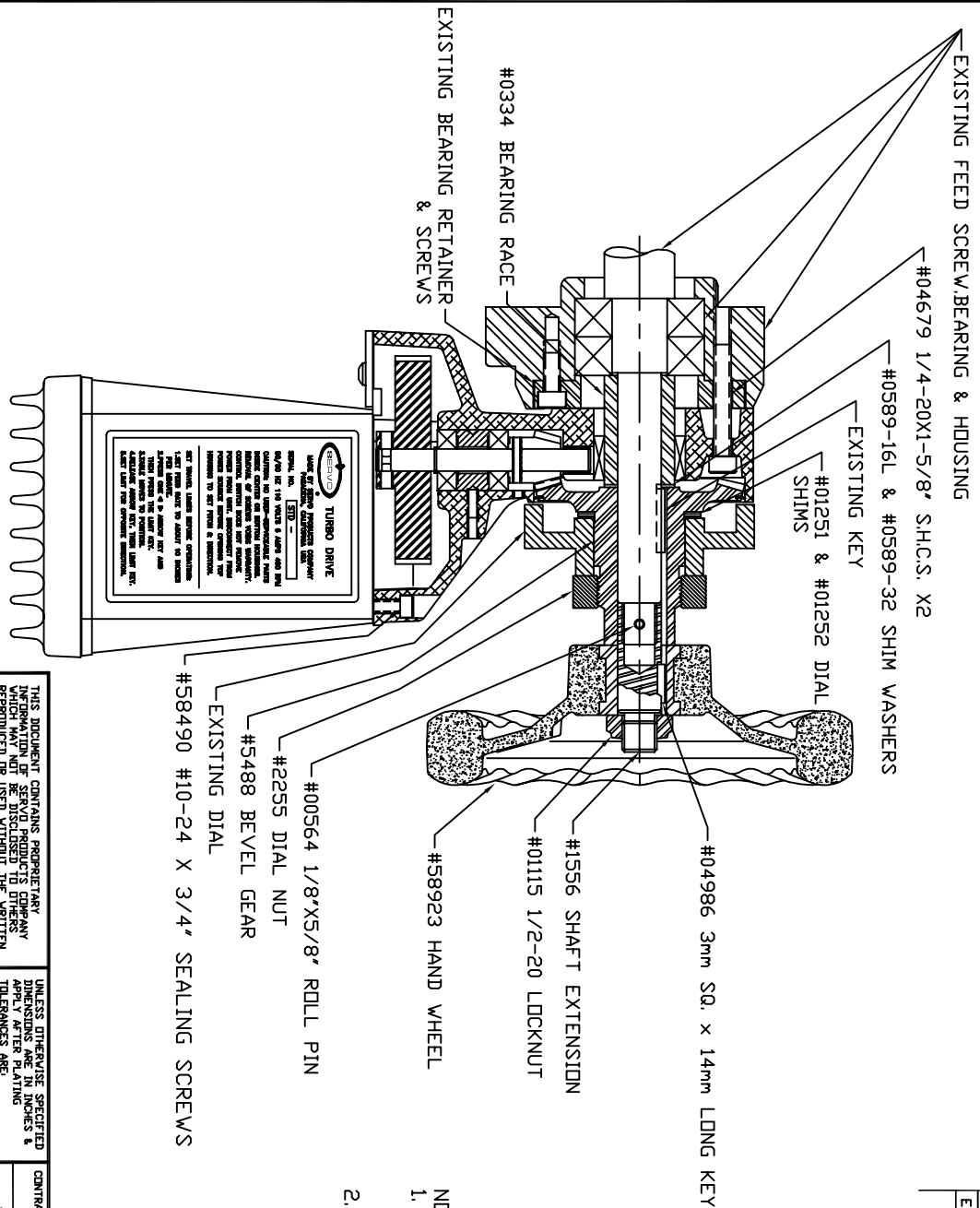

- NOTES:
1. REVIEW ALL INSTALLATION INSTRUCTIONS AND POWER FEED OPERATIONS BEFORE TURNING ON SERVO POWER FEED.
 2. REMOVAL OF MOTOR, KEY PAD OR BOTTOM HOUSING VOIDS THE WARRANTY.

UNLESS OTHERWISE SPECIFIED PERPENDICULARITY, PARALLELISM, STRAIGHTNESS, FLATNESS, ROUNDNESS, CONCENTRICITY, CYLINDRICITY TO BE WITHIN .01 TOTAL OR .040/√L. REMOVE SHARP CORNERS AND EDGES .005 MIN. DRAWING STANDARD PER ANSI Y14.5M-1982

THIS DOCUMENT CONTAINS PROPRIETARY INFORMATION OF SERVO PRODUCTS COMPANY WHICH MAY NOT BE DISCLOSED TO OTHERS WITHOUT THE WRITTEN AUTHORITY FROM AN OFFICER OF SERVO PRODUCTS COMPANY.

UNLESS OTHERWISE SPECIFIED DIMENSIONS ARE IN INCHES & TOLERANCES ARE AS FOLLOWS: FRACTIONS DECIMALS ANGLES ± 1/64 ± .005 ± .005 ± 1/2°

CONTRACT NO.	APPROVALS	DATE
	DRAWN T. KU	01/11/99
	CHECKED	

FINISH	DID NOT SCALE DRAWING	COMPUTER NO.

APPLICATION	USED IN
NEXT ASSY	

SERVO PRODUCTS COMPANY
433 N. FAIR OAKS AVE., PASADENA CALIFORNIA 91103

INSTALLATION DRAWING
MODEL 9522T

SIZE	CODE IDENT NO.	DRAWING NO.	REV.
B	0800-80742	NB-58626	B

SCALE 1/2 SHEET 1 OF 1