



# **TURBO DRIVE INSTALLATION**

## **MODEL 3750T CROSS FEED**

### **Sharp Mill & Others**

➔ **NOTE** This Turbo Drive Cross Feed is configured for mounting the feed on the front of the knee with the keypad facing right. The lead screw pitch is 5 turns per inch left hand. See **CAUTION** below before changing anything!

#### **CAUTION**

The Turbo Drive power cable should be left **unplugged** until the drive is properly installed on the lead screw.

See the **Operation** manual to reverse the direction of travel or to change the lead screw pitch default. Turn **off** the Turbo Drive and **remove** the power plug from the wall before you attempt to change any jumpers or reverse the top housing.

#### **WARNINGS**

**DO NOT** install and operate this power feed without safety handwheel Servo #58923 on the front side of the cross. This is required to prevent injury.

**Check handwheel clearances before operation.**

Clearances between the surfaces of the handwheel and the non-moving parts of the equipment on which the handwheel is installed must be at least one-fourth inch (1/4") to prevent injury.

**Do not operate** without proper clearance!

Prevent contact during fast traverses.

#### **WARRANTY CAUTION**

There are **NO** user-serviceable parts inside the center or bottom housings. Removal of the motor, keyboard, or bottom housing screws **voids** the warranty.

---

#### **REFERENCE DRAWINGS ENCLOSED**

NA-58496	Bevel Gear Installation
NB-58535	Turbo Drive Installation
0800-80678	Turbo Drive Operation manual

---

#### **PREPARATION**

**Step 1:** Gather together the following items that you will need to complete this installation.

- a) 3/8" electric hand drill
- b) #7 drill, 11/64" drill, 3/16" drill
- c) 1/4-20 tap
- d) 9/32" diameter transfer punch

- e) ball peen hammer & support piece
- f) flat file
- g) 3/4" socket wrench
- h) set of inch hex wrenches
- i) grease
- j) masking tape
- k) clean shop rag

**Step 2:** Clean the power feed mounting area completely.

**Step 3:** Remove the nut, handle, and dial assembly from the front end of the cross. Keep the dial for reuse later.

## **MOUNTING HARDWARE INSTALLATION**

**Step 1:** Slip the bearing race #0714 onto the lead screw shaft.

**Step 2:** Slip the adaptor #57237 over the bearing race and slide both together to locate the adaptor against the cross bracket (bearing housing).

**Step 3:** Line up the mounting holes on the adaptor such that the power feed can be mounted vertically. Using a 9/32" diameter transfer punch, transfer the three mounting holes to the bearing retainer.

**Step 4:** Remove the adaptor and the bearing race. Mask the bearing in the bracket. Then drill and tap 1/4-20 UNC threads through the bearing retainer. Clean thoroughly. Do **not** use air.

**Step 5:** Lubricate the shaft with a light coat of grease. Slip the bearing race back onto the shaft. Then slip the adaptor over the race to center it with the shaft. Keeping the portion of the race sticking out beyond the counterbored end of the adaptor so that it can be removed later, slide both pieces to locate the adaptor against the cross bracket. Secure the adaptor with three 1/4-20 x 1-3/8 long socket head cap screws provided. Remove the bearing race.

**Step 6:** Slip spacer #6873 onto the shaft followed by the bearing race.

## **SHAFT EXTENSION AND TURBO DRIVE INSTALLATION**

**Step 1:** Screw on the shaft extension #57099 onto the lead screw and tighten.

**Step 2:** Following the existing pilot hole, drill through the shaft extension using an 11/64" diameter drill. Finish the hole using a 3/16" diameter drill.

**Step 3:** Support the other side of the hole with a heavy piece of metal and hammer in the #00596 roll pin. File smooth and clean thoroughly.

*Step 4:* Slide the Turbo Drive onto the bearing race and push against the adaptor. Secure with two 1/4-20 x 1-1/8" long socket head cap screws.

*IF:* If the bearing race is not flush with the needle bearing in the unit within  $\pm.05$ ", then either shim behind the race or machine the spacer to correctly locate the race.

## **BEVEL GEAR INSTALLATION**

*Step 1:* Follow the drawing NA-58496 for installation of the bevel gear. Adjust for proper gear backlash.

## **DIAL AND HANDWHEEL INSTALLATION**

*Step 1:* After getting the proper gear backlash, the dial should be adjusted to obtain .005" spacing from the face of the power feed. This is important in order to keep chips from entering the gear train. Three plastic (.030" thick) and five brass (.005" thick) washers are provided for this. Shim as required.

*Step 2:* In the following sequence, install the key, spacer #57716, dial and dial nut #2255. Slide the handwheel #58923 in place and tighten with 1/2-20 locknut #01115.

## **TURBO DRIVE OPERATION**

See the separate **Servo Turbo Drive Operation** manual for complete operating instructions. Plug the unit into a properly grounded three-wire outlet supplying 110 volt single phase 50/60 Hz 6 amp power. Turn the control switch ON and follow the instructions in the manual or on the **Quick Reference** sheet for setting limits.

### **SERVO PRODUCTS COMPANY**

433 North Fair Oaks Avenue, Pasadena, CA 91103 USA  
Phone: 800.521.7359 or 626.796.2460 Fax: 626.796.3845

Web: [www.servoproductsco.com](http://www.servoproductsco.com)

If service is required, call Servo Products Company.

DO NOT PLUG IN POWER UNTIL ALL STEPS ARE COMPLETED.

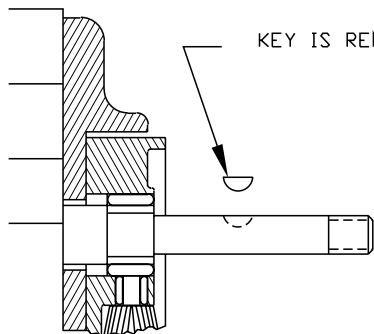

KEY IS REMOVED DURING SHIMMING

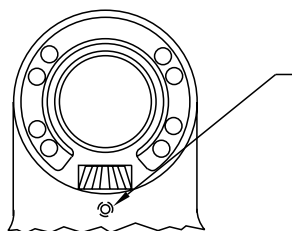

TIGHTEN SLIGHTLY (HOLDS BEVEL PINION STATIONARY DURING SHIMMING.) (TIGHTEN UPPER ONE ONLY)

**STEP 1**  
**PREPARATION**

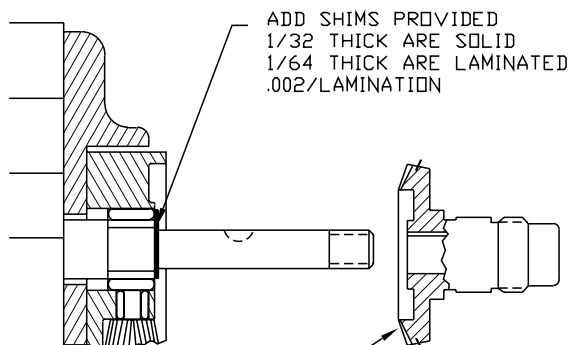

ADD SHIMS PROVIDED  
1/32 THICK ARE SOLID  
1/64 THICK ARE LAMINATED  
.002/LAMINATION

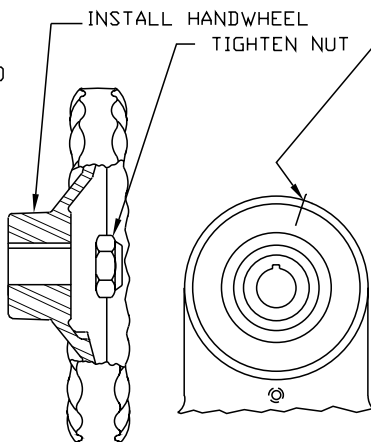

INSTALL HANDWHEEL

TIGHTEN NUT

SCRIBE ACROSS GEAR & HOUSING WHILE PUSHING GEAR AGAINST ONE SIDE OF THE BACKLASH

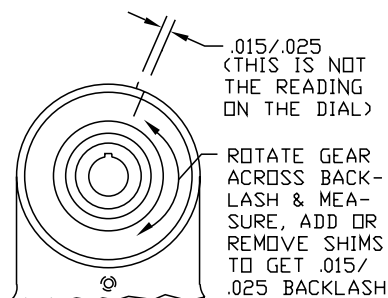

.015/.025  
(THIS IS NOT THE READING ON THE DIAL)

ROTATE GEAR ACROSS BACKLASH & MEASURE, ADD OR REMOVE SHIMS TO GET .015/.025 BACKLASH

PUSH BEVEL GEAR AGAINST SHIMS.

**STEP 2**  
**SHIMMING BEVEL GEAR**

**CAUTION:** IF BACKLASH IS NOT PROPERLY SET BEFORE TURNING UNIT ON, BEVEL GEAR MAY BE DESTROYED.

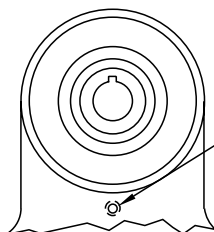

LOOSEN SETSCREW

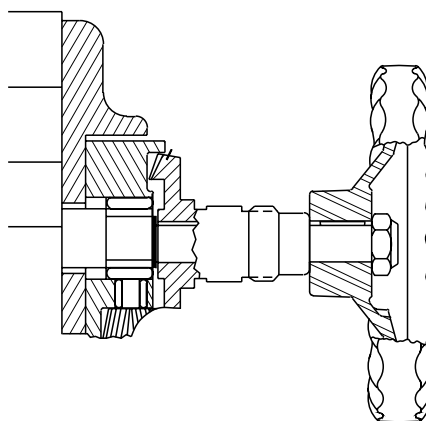

MANUALLY TURN HANDWHEEL. IF EXCESSIVE GEAR NOISE OR BINDING OCCURS, SHIMS NEED TO BE ADDED OR REMOVED, WHEN RE-SHIMMING, REPEAT STEPS 1 AND 2.

**STEP 3**  
**DOUBLE CHECK OF SHIMMING**

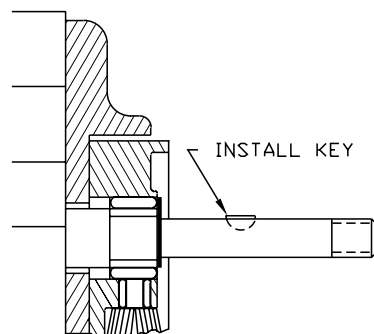

INSTALL KEY

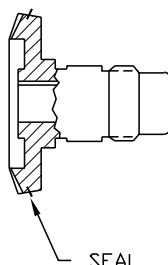

SEAL

REMOVE GEAR, PACK WITH GREASE. (DO NOT USE SILICONE TYPE GREASE) REPLACE GEAR. (DO NOT LOSE ANY SHIMS)

PICTURES IN THIS DRAWING ARE FOR REFERENCE ONLY. SEE INSTALLATION DRAWING OF CORRESPONDING MODEL FOR EXACT PARTS CONFIGURATION.



SERVO PRODUCTS COMPANY

BEVEL GEAR INSTALLATION

NA-58496

**STEP 4**  
**LUBRICATION**

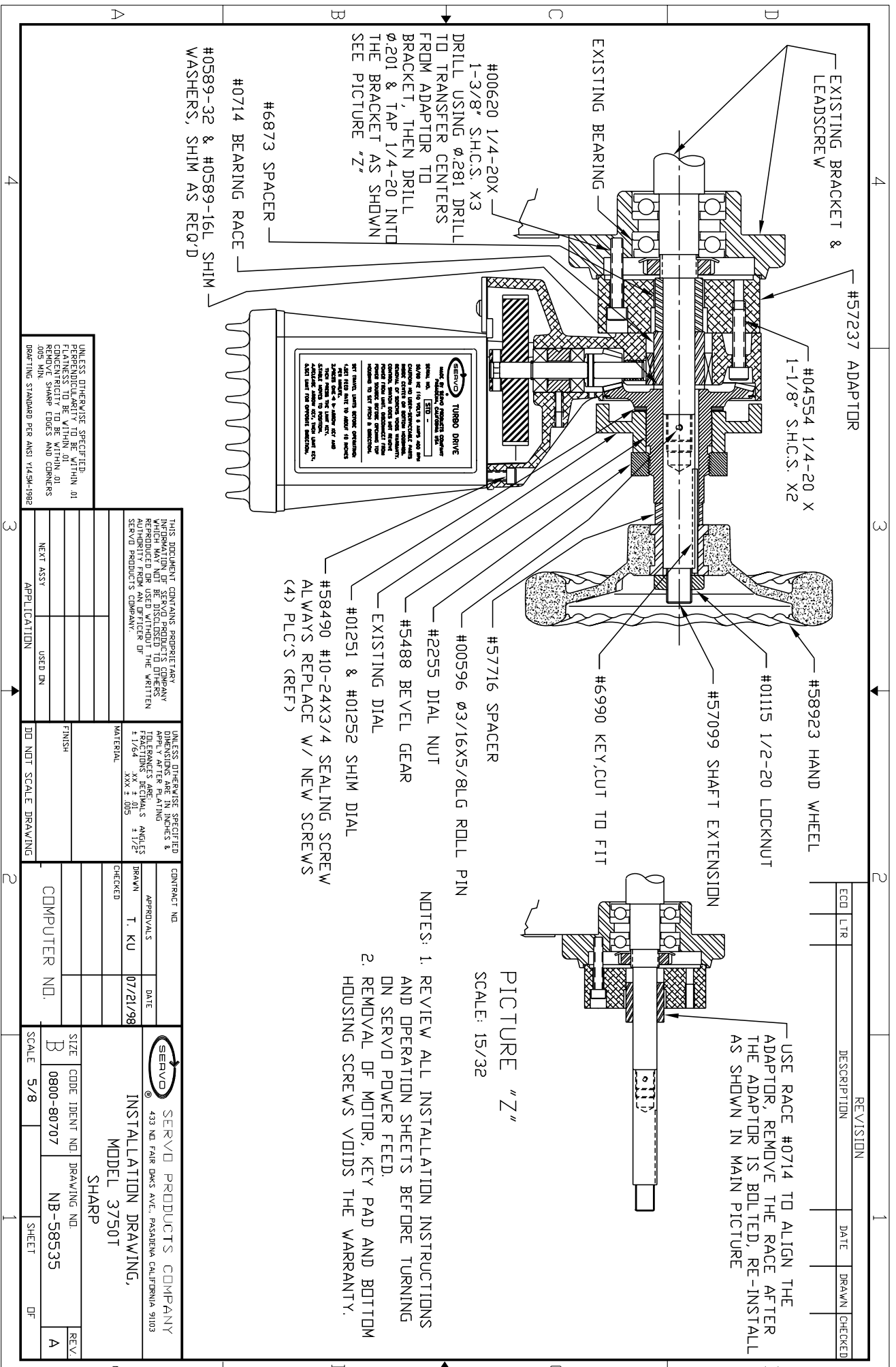

REV	DESCRIPTION	DATE	DRAWN	CHECKED

THIS DOCUMENT CONTAINS PROPRIETARY INFORMATION AND IS THE PROPERTY OF SERVO PRODUCTS COMPANY WHICH MAY NOT BE DISCLOSED TO OTHERS WITHOUT THE WRITTEN PERMISSION OF SERVO PRODUCTS COMPANY.		UNLESS OTHERWISE SPECIFIED DIMENSIONS ARE IN INCHES & FRACTIONS ARE ANGLES ± 1/2° ± 0.05		CONTRACT NO.
UNLESS OTHERWISE SPECIFIED DIMENSIONS ARE IN INCHES & FRACTIONS ARE ANGLES ± 1/2° ± 0.05		MATERIAL		APPROVALS
UNLESS OTHERWISE SPECIFIED DIMENSIONS ARE IN INCHES & FRACTIONS ARE ANGLES ± 1/2° ± 0.05		FINISH		DATE
UNLESS OTHERWISE SPECIFIED DIMENSIONS ARE IN INCHES & FRACTIONS ARE ANGLES ± 1/2° ± 0.05		CHECKED		07/21/98
UNLESS OTHERWISE SPECIFIED DIMENSIONS ARE IN INCHES & FRACTIONS ARE ANGLES ± 1/2° ± 0.05		DRAWN		T. KU
UNLESS OTHERWISE SPECIFIED DIMENSIONS ARE IN INCHES & FRACTIONS ARE ANGLES ± 1/2° ± 0.05		USED ON		COMPUTER NO.
UNLESS OTHERWISE SPECIFIED DIMENSIONS ARE IN INCHES & FRACTIONS ARE ANGLES ± 1/2° ± 0.05		APPLICATION		SIZE
UNLESS OTHERWISE SPECIFIED DIMENSIONS ARE IN INCHES & FRACTIONS ARE ANGLES ± 1/2° ± 0.05		NEXT ASSY		CODE IDENT NO.
UNLESS OTHERWISE SPECIFIED DIMENSIONS ARE IN INCHES & FRACTIONS ARE ANGLES ± 1/2° ± 0.05		DRAWING NO.		DRAWING NO.
UNLESS OTHERWISE SPECIFIED DIMENSIONS ARE IN INCHES & FRACTIONS ARE ANGLES ± 1/2° ± 0.05		SCALE		NB-58535
UNLESS OTHERWISE SPECIFIED DIMENSIONS ARE IN INCHES & FRACTIONS ARE ANGLES ± 1/2° ± 0.05		SHEET		REV.
UNLESS OTHERWISE SPECIFIED DIMENSIONS ARE IN INCHES & FRACTIONS ARE ANGLES ± 1/2° ± 0.05		OF		A

SERVO PRODUCTS COMPANY  
 433 N. FAIR DMES AVE., PASADENA CALIFORNIA 91103  
 INSTALLATION DRAWING,  
 MODEL 3750T  
 SHARP