



TURBO DRIVE INSTALLATION

MODEL 1552T CROSS FEED

Lagun Mill

➔ **NOTE** This Turbo Drive Cross Feed is configured for mounting the feed on the front of the knee with the keypad facing right. The lead screw pitch is 5 turns per inch left hand. See **CAUTION** below before changing anything!

CAUTION

The Turbo Drive power cable should be left **unplugged** until the drive is properly installed on the lead screw.

See the **Operation** manual to reverse the direction of travel or to change the lead screw pitch default. Turn **off** the Turbo Drive and **remove** the power plug from the wall before you attempt to change any jumpers or reverse the top housing.

WARNINGS

DO NOT install and operate this power feed without safety handwheel Servo #58923 on the front side of the cross. This is required to prevent injury.

Check handwheel clearances before operation.

Clearances between the surfaces of the handwheel and the non-moving parts of the equipment on which the handwheel is installed must be at least one-fourth inch (1/4") to prevent injury.

Do not operate without proper clearance!

Prevent contact during fast traverses.

WARRANTY CAUTION

There are **NO** user-serviceable parts inside the center or bottom housings. Removal of the motor, keyboard, or bottom housing screws **voids** the warranty.

REFERENCE DRAWINGS ENCLOSED

NA-58496	Bevel Gear Installation
NB-58980	Turbo Drive Installation
0800-80678	Turbo Drive Operation manual

PREPARATION

Step 1: Gather together the following items that you will need to complete this installation.

- a) 3/8" electric hand drill
- b) #7 drill, 11/64" drill, 3/16" drill
- c) 1/4-20 tap
- d) 9/32" (.281") diameter transfer punch

- e) ball peen hammer & support piece
- f) flat file
- g) 3/4" socket wrench
- h) set of inch hex wrenches
- i) grease
- j) masking tape
- k) clean shop rag

Step 2: Clean the power feed mounting area completely.

Step 3: Remove the nut, handle, and dial assembly from the front of the knee. Keep the dial for reuse later.

MOUNTING HARDWARE INSTALLATION

Step 1: Slip the spacers #6559 and #0477 onto the lead screw shaft as shown, followed by bearing race #1178.

Step 2: Slip the adaptor #6742 and feed over the bearing race and slide both together to locate against the cross bracket (bearing housing).

Step 3: Line up the mounting holes on the adaptor and the feed such that the power feed can be mounted vertically. Using a 9/32" diameter transfer punch, transfer three mounting holes from the feed to the bearing retainer.

Step 4: Remove the unit and all the parts just installed. Remove the bearing retainer to drill and tap 1/4-20 UNC threads through at the transferred spots. Reinstall with #05955 low head screws provided.

Step 5: Lubricate the shaft with a light coat of grease. Slip the spacers and the bearing race back onto the shaft.

SHAFT EXTENSION AND TURBO DRIVE INSTALLATION

Step 1: Screw on the shaft extension #0772 onto the lead screw and tighten.

Step 2: Following the existing pilot hole, drill through the shaft extension using an 11/64" diameter drill. Finish the hole using a 3/16" diameter drill.

Step 3: Support the other side of the hole with a heavy piece of metal and hammer in the #00596 roll pin. File smooth and clean thoroughly.

Step 4: Slide the adaptor #6742, shroud #58522 and the Turbo Drive onto the bearing race and push against the bracket. Secure with two 1/4-20 x 1-5/8" long socket head cap screws.

IF: If the bearing race is not flush with the needle bearing in the unit within $\pm.05$ ", then either shim behind the race or machine the spacer to correctly locate the race.

BEVEL GEAR INSTALLATION

Step 1: Follow the drawing NA-58496 for installation of the bevel gear. Adjust for proper gear backlash.

DIAL AND HANDWHEEL INSTALLATION

Step 1: After getting the proper gear backlash, the dial should be adjusted to obtain .005" spacing from the face of the power feed. This is important in order to keep chips from entering the gear train. Three plastic (.030" thick) and five brass (.005" thick) washers are provided for this. Shim as required.

Step 2: In the following sequence, install the key, dial and dial nut #2255. Slide the handwheel #58923 in place and tighten with 1/2-20 locknut #01115.

TURBO DRIVE OPERATION

See the separate **Servo Turbo Drive Operation** manual for complete operating instructions. Plug the unit into a properly grounded three-wire outlet supplying 110 volt single phase 50/60 Hz 6 amp power. Turn the control switch ON and follow the instructions in the manual or on the **Quick Reference** sheet for setting limits.

SERVO PRODUCTS COMPANY

433 North Fair Oaks Avenue, Pasadena, CA 91103 USA
Phone: 800.521.7359 or 626.796.2460 Fax: 626.796.3845

Web: www.servoproductsco.com

If service is required, call Servo Products Company.

DO NOT PLUG IN POWER UNTIL ALL STEPS ARE COMPLETED.

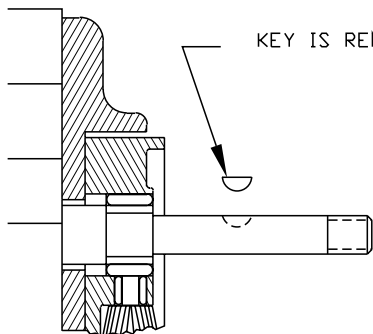

KEY IS REMOVED DURING SHIMMING

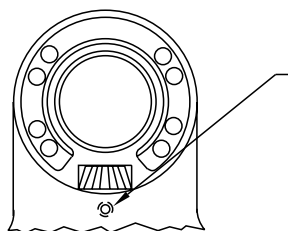

TIGHTEN SLIGHTLY (HOLDS BEVEL PINION STATIONARY DURING SHIMMING.)
(TIGHTEN UPPER ONE ONLY)

STEP 1
PREPARATION

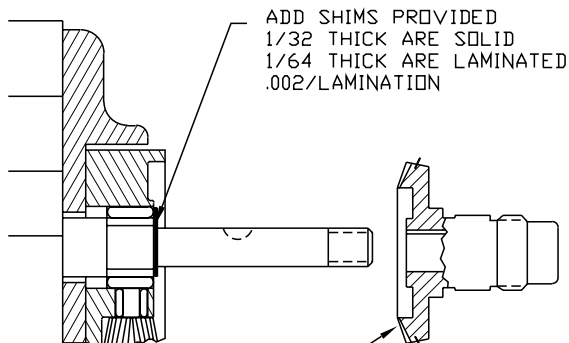

ADD SHIMS PROVIDED
1/32 THICK ARE SOLID
1/64 THICK ARE LAMINATED
.002/LAMINATION

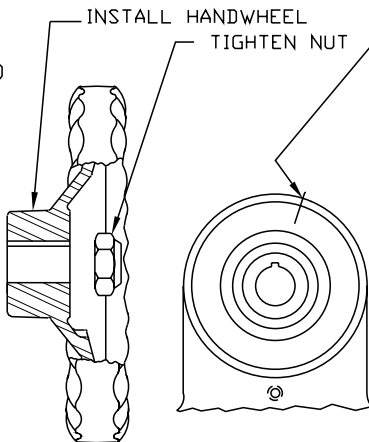

INSTALL HANDWHEEL

TIGHTEN NUT

SCRIBE ACROSS GEAR & HOUSING WHILE PUSHING GEAR AGAINST ONE SIDE OF THE BACKLASH

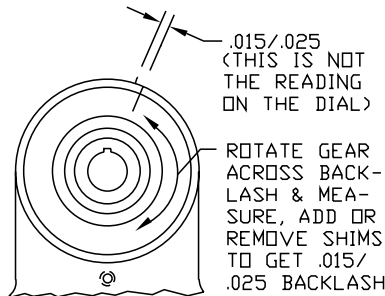

.015/.025
(THIS IS NOT THE READING ON THE DIAL)

ROTATE GEAR ACROSS BACKLASH & MEASURE, ADD OR REMOVE SHIMS TO GET .015/.025 BACKLASH

PUSH BEVEL GEAR AGAINST SHIMS.

STEP 2
SHIMMING BEVEL GEAR

CAUTION: IF BACKLASH IS NOT PROPERLY SET BEFORE TURNING UNIT ON, BEVEL GEAR MAY BE DESTROYED.

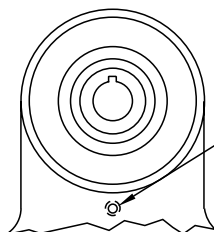

LOOSEN SETSCREW

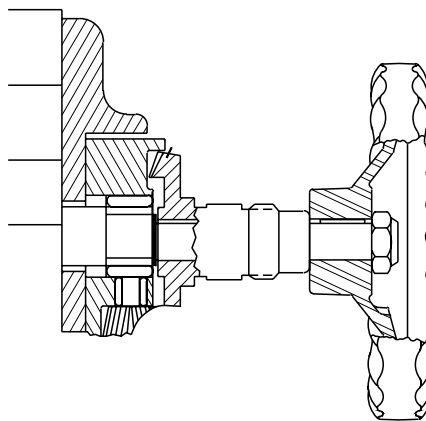

MANUALLY TURN HANDWHEEL. IF EXCESSIVE GEAR NOISE OR BINDING OCCURS, SHIMS NEED TO BE ADDED OR REMOVED, WHEN RE-SHIMMING, REPEAT STEPS 1 AND 2.

STEP 3
DOUBLE CHECK OF SHIMMING

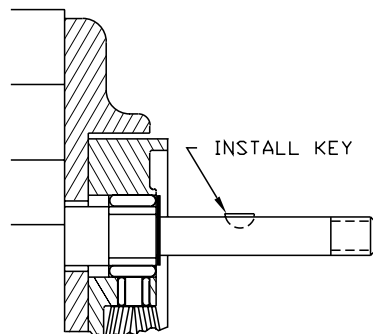

INSTALL KEY

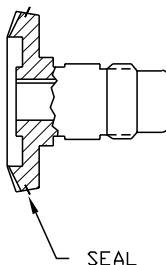

SEAL

STEP 4
LUBRICATION

REMOVE GEAR, PACK WITH GREASE. (DO NOT USE SILICONE TYPE GREASE) REPLACE GEAR. (DO NOT LOSE ANY SHIMS)

PICTURES IN THIS DRAWING ARE FOR REFERENCE ONLY. SEE INSTALLATION DRAWING OF CORRESPONDING MODEL FOR EXACT PARTS CONFIGURATION.



SERVO PRODUCTS COMPANY

BEVEL GEAR INSTALLATION

NA-58496

REVISION			DATE	DRAWN	CHECKED
ECD	LTR	DESCRIPTION			

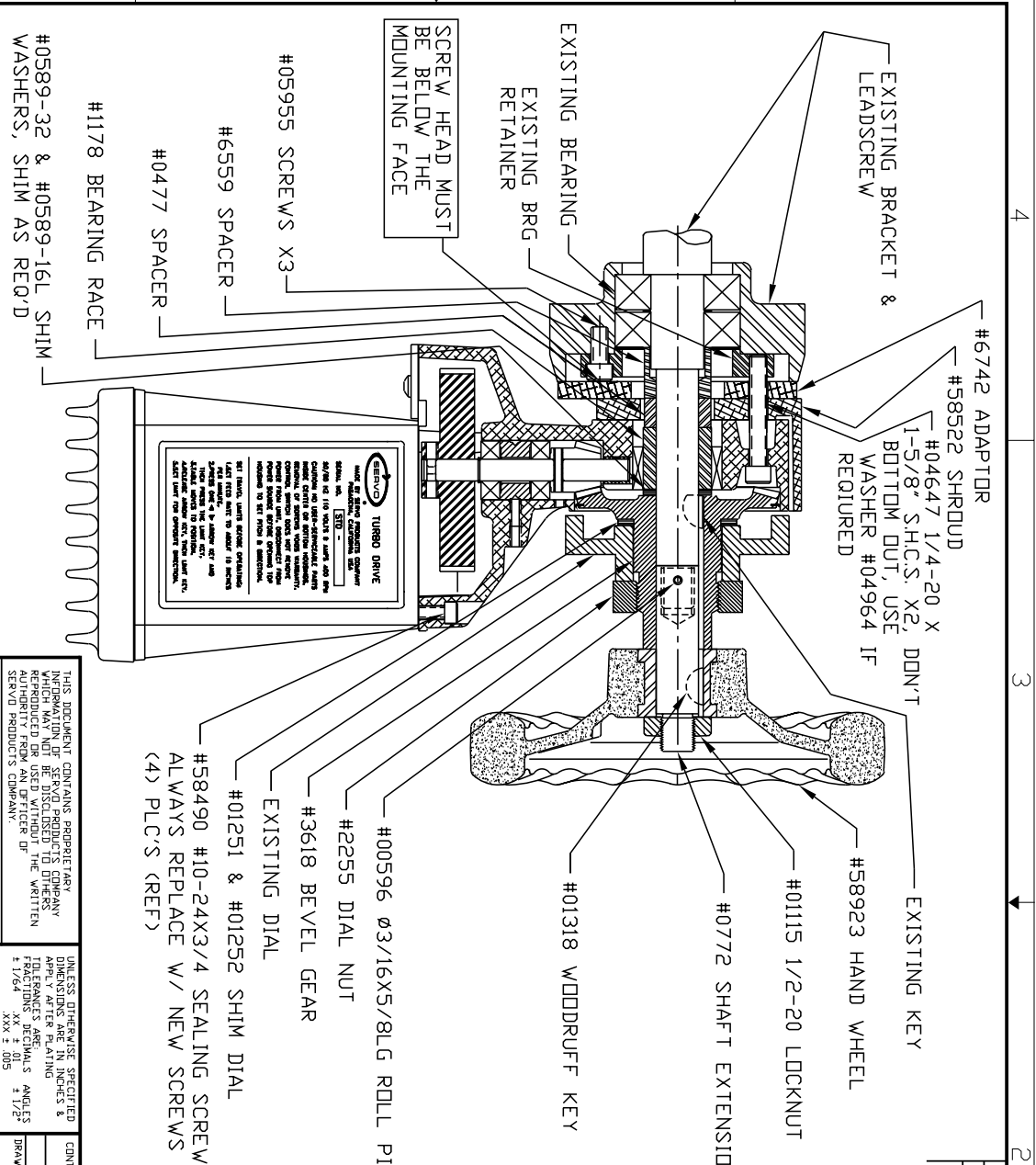

UNLESS OTHERWISE SPECIFIED, PERIODICITY TO BE WITHIN .01 CONCENTRICITY TO BE WITHIN .01 REMOVE SHARP EDGES AND CORNERS .005 MIN.
DRAWING STANDARD PER ANSI Y14.5M-1982

THIS DOCUMENT CONTAINS PROPRIETARY INFORMATION AND IS THE PROPERTY OF SERVOD PRODUCTS COMPANY WHICH MAY NOT BE DISCLOSED TO OTHERS REPRODUCED OR USED WITHOUT THE WRITTEN PERMISSION FROM THE APPLICATOR OR SERVOD PRODUCTS COMPANY.

UNLESS OTHERWISE SPECIFIED DIMENSIONS ARE IN INCHES & TOLERANCES ARE ANGLES ± 1/2° ± 1/64\"/>

APPLICATOR	USED ON	DID NOT SCALE DRAWING	CHECKED
FINISH			

- #58923 HAND WHEEL
- #01115 1/2-20 LOCKNUT
- #0772 SHAFT EXTENSION
- #01318 WOODRUFF KEY
- EXISTING KEY
- #58923 HAND WHEEL
- #01115 1/2-20 LOCKNUT
- #0772 SHAFT EXTENSION
- #01318 WOODRUFF KEY
- #00596 Ø3/16X5/8LG ROLL PIN
- #2255 DIAL NUT
- #3618 BEVEL GEAR
- EXISTING DIAL
- #01251 & #01252 SHIM DIAL
- #58490 #10-24X3/4 SEALING SCREW ALWAYS REPLACE W/ NEW SCREWS (4) PLC'S (REF)

NOTES:

1. REVIEW ALL INSTALLATION INSTRUCTIONS AND OPERATION SHEETS BEFORE TURNING ON SERVO POWER FEED.
2. REMOVAL OF MOTOR, KEY PAD AND BOTTOM HOUSING SCREWS VOIDS THE WARRANTY.

APPROVALS	DATE	SIZE	CODE	IDENT NO.	DRAWING NO.	REV.
M.WU	4/12/00	B	0800-80816		NB-58980	
CHECKED		SCALE	5/8			OF

SERVOD PRODUCTS COMPANY
433 N. FAIR GMS AVE., PASADENA CALIFORNIA 91103
INSTALLATION DRAWING,
MODEL 1552T
STD, LAGUN