

REVISION		DATE	DRAWN	CHECKED
ECD	LTR	DESCRIPTION		

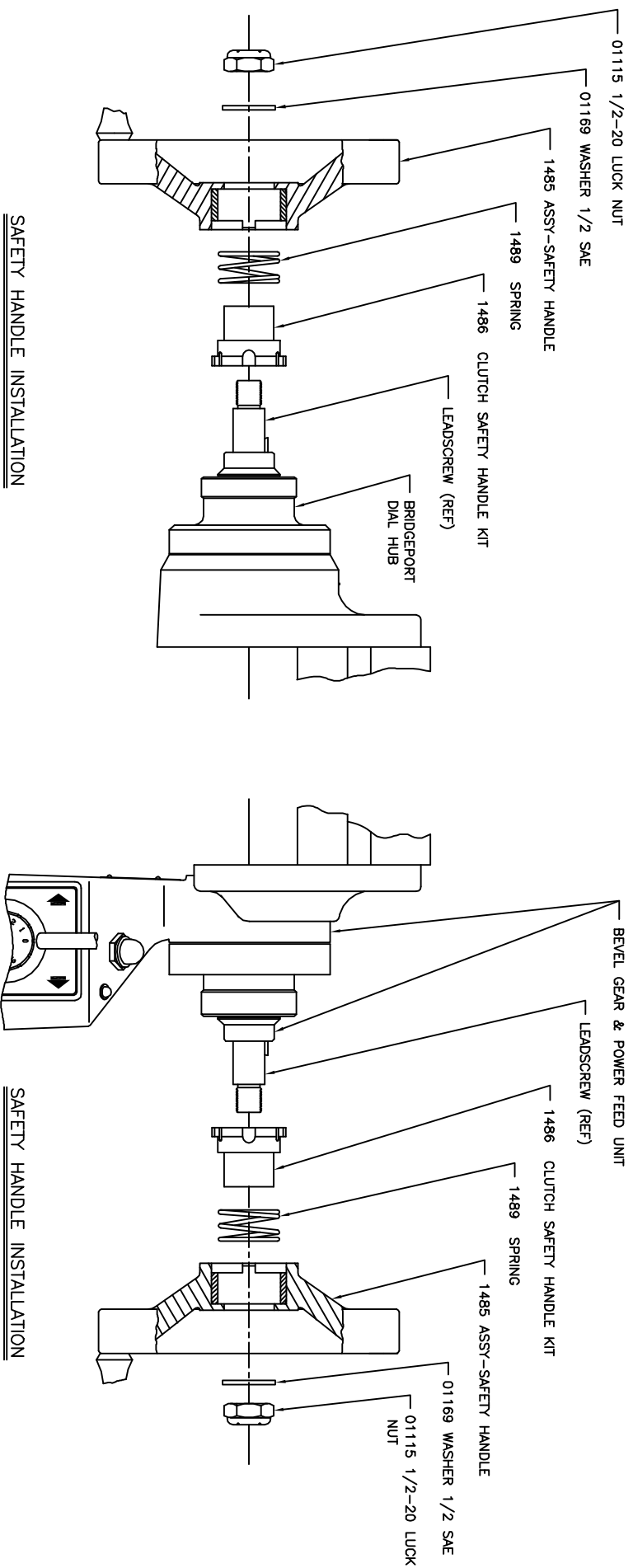

**SAFETY HANDLE INSTALLATION**  
TYPICAL FOR EITHER END OF  
TABLE WITHOUT POWER FEED

**SAFETY HANDLE INSTALLATION**  
WITH SERVO POWER FEED RIGHT  
END OF MILL TABLE ONLY

NOTE: BRIDGEPORT MILL SHOWN.

UNLESS OTHERWISE SPECIFIED,  
DIMENSIONS ARE IN INCHES &  
TOLERANCES ARE AS FOLLOWS:  
FRACTIONS DECIMALS ANGLES  
± 1/64 ± .005 ± .005 ± 1/2°  
MATERIAL FINISH NOTED  
DID NOT SCALE DRAWING

THIS DOCUMENT CONTAINS PROPRIETARY  
INFORMATION OF SERVO PRODUCTS COMPANY  
WHICH MAY NOT BE DISCLOSED TO OTHERS  
WITHOUT THE WRITTEN AUTHORITY FROM AN OFFICER OF  
SERVO PRODUCTS COMPANY.

CONTRACT NO.	APPROVALS	DATE
	M. WU	12/28/01
CHECKED		

**SERVO PRODUCTS COMPANY**  
34940 LAKELAND BLVD, EASTLAKE, OH 44095

**SAFETY HANDLE, "SH" KIT  
INSTALLATION DRAWING  
MODEL 620**

SIZE CODE IDENT NO. DRAWING NO. REV.  
B 0800-80088 NB-1481

SCALE 1/2 SHEET DF

UNLESS OTHERWISE SPECIFIED,  
DIMENSIONS ARE IN INCHES &  
TOLERANCES ARE AS FOLLOWS:  
FRACTIONS DECIMALS ANGLES  
± 1/64 ± .005 ± .005 ± 1/2°  
MATERIAL FINISH NOTED  
DID NOT SCALE DRAWING

UNLESS OTHERWISE SPECIFIED,  
DIMENSIONS ARE IN INCHES &  
TOLERANCES ARE AS FOLLOWS:  
FRACTIONS DECIMALS ANGLES  
± 1/64 ± .005 ± .005 ± 1/2°  
MATERIAL FINISH NOTED  
DID NOT SCALE DRAWING

CONTRACT NO.	APPROVALS	DATE
	M. WU	12/28/01
CHECKED		

**SERVO PRODUCTS COMPANY**  
34940 LAKELAND BLVD, EASTLAKE, OH 44095

**SAFETY HANDLE, "SH" KIT  
INSTALLATION DRAWING  
MODEL 620**

SIZE CODE IDENT NO. DRAWING NO. REV.  
B 0800-80088 NB-1481

SCALE 1/2 SHEET DF